

Write your name here

Surname

Other names

Pearson Edexcel
International
Advanced Level

Centre Number

--	--	--	--	--	--

Candidate Number

--	--	--	--	--	--

Physics

Advanced Subsidiary
Unit 3: Exploring Physics

Tuesday 26 January 2016 – Morning
Time: 1 hour 20 minutes

Paper Reference

WPH03/01

You do not need any other materials.

Total Marks

Instructions

- Use **black** ink or ball-point pen.
- **Fill in the boxes** at the top of this page with your name, centre number and candidate number.
- Answer **all** questions.
- Answer the questions in the spaces provided – *there may be more space than you need.*

Information

- The total mark for this paper is 40.
- The marks for **each** question are shown in brackets – *use this as a guide as to how much time to spend on each question.*
- The list of data, formulae and relationships is printed at the end of this booklet.
- Candidates may use a scientific calculator.

Advice

- Read each question carefully before you start to answer it.
- Keep an eye on the time.
- Try to answer every question.
- Check your answers if you have time at the end.

Turn over ►

P46953A

©2016 Pearson Education Ltd.

6/6/6/



PEARSON

SECTION A

Answer ALL questions.

For questions 1–5, in Section A, select one answer from A to D and put a cross in the box . If you change your mind put a line through the box and then mark your new answer with a cross .

1 Which of the following is a base SI unit?

- A ampere
- B newton
- C pascal
- D watt

(Total for Question 1 = 1 mark)

2 The diagram below shows a micrometer screw gauge which has been used to measure the width of a piece of metal.

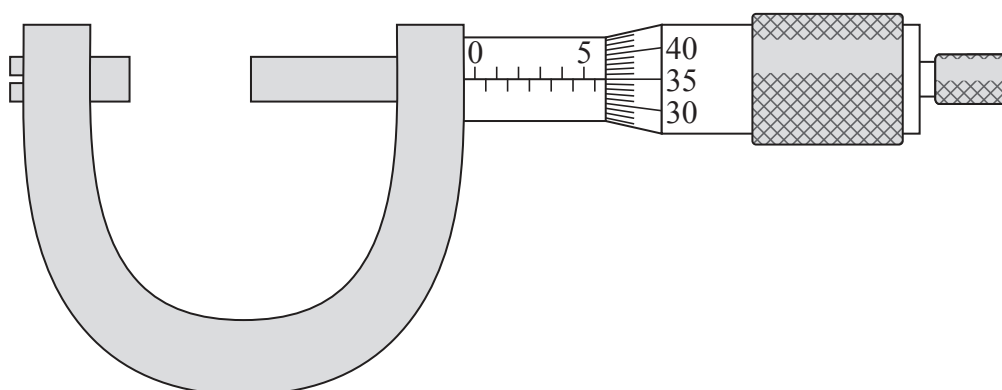

Which is the correct reading of the gauge in millimetres?

- A 5.135
- B 5.235
- C 5.85
- D 6.35

(Total for Question 2 = 1 mark)

DO NOT WRITE IN THIS AREA

DO NOT WRITE IN THIS AREA

DO NOT WRITE IN THIS AREA



DO NOT WRITE IN THIS AREA

DO NOT WRITE IN THIS AREA

DO NOT WRITE IN THIS AREA

Questions 3, 4 and 5 refer to the circuit and graph below. The variable resistor is used to vary the current I and the potential difference V is measured.

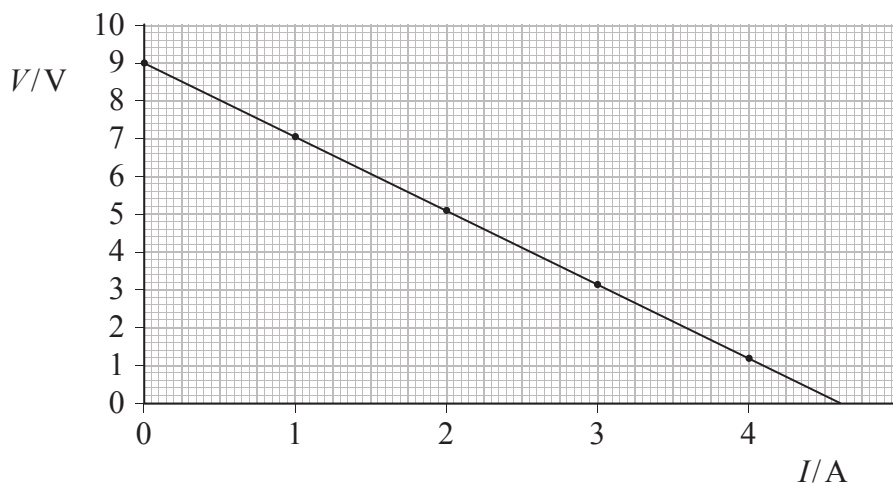
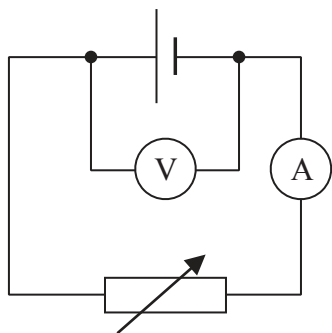

3 Which is the correct description of the relationship between V and I ?

- A They are directly proportional.
- B They are inversely proportional.
- C There is a linear relationship.
- D There is a non-linear relationship.

(Total for Question 3 = 1 mark)

4 Which of the following would give the e.m.f. of the cell?

- A the area under the graph
- B the magnitude of the gradient
- C the intercept on the I axis
- D the intercept on the V axis

(Total for Question 4 = 1 mark)

5 Which of the following is the magnitude of the gradient of the graph?

- A 2.09
- B 1.96
- C 0.511
- D 0.478

(Total for Question 5 = 1 mark)

TOTAL FOR SECTION A = 5 MARKS



SECTION B

Answer ALL questions in the spaces provided.

6 In an experiment to determine the density of a metal a student recorded her final value as $8700 \pm 200 \text{ kg m}^{-3}$.

(a) State the range of her measurements.

(1)

.....
.....

(b) Calculate the percentage uncertainty in her measurement.

(2)

.....
.....
.....

Percentage uncertainty =

(c) The student was given the following table of values.

Metal	Density / kg m^{-3}
brass	8440
bronze	8810
copper	8930

State which metal she was using.

(1)

.....

(Total for Question 6 = 4 marks)

DO NOT WRITE IN THIS AREA

DO NOT WRITE IN THIS AREA

DO NOT WRITE IN THIS AREA



DO NOT WRITE IN THIS AREA

DO NOT WRITE IN THIS AREA

DO NOT WRITE IN THIS AREA

BLANK PAGE



- 7 A student is asked to determine the efficiency of a 9 V electric motor when it is used to lift a 1 kg mass at a steady speed. The diagram below shows the apparatus to be used.

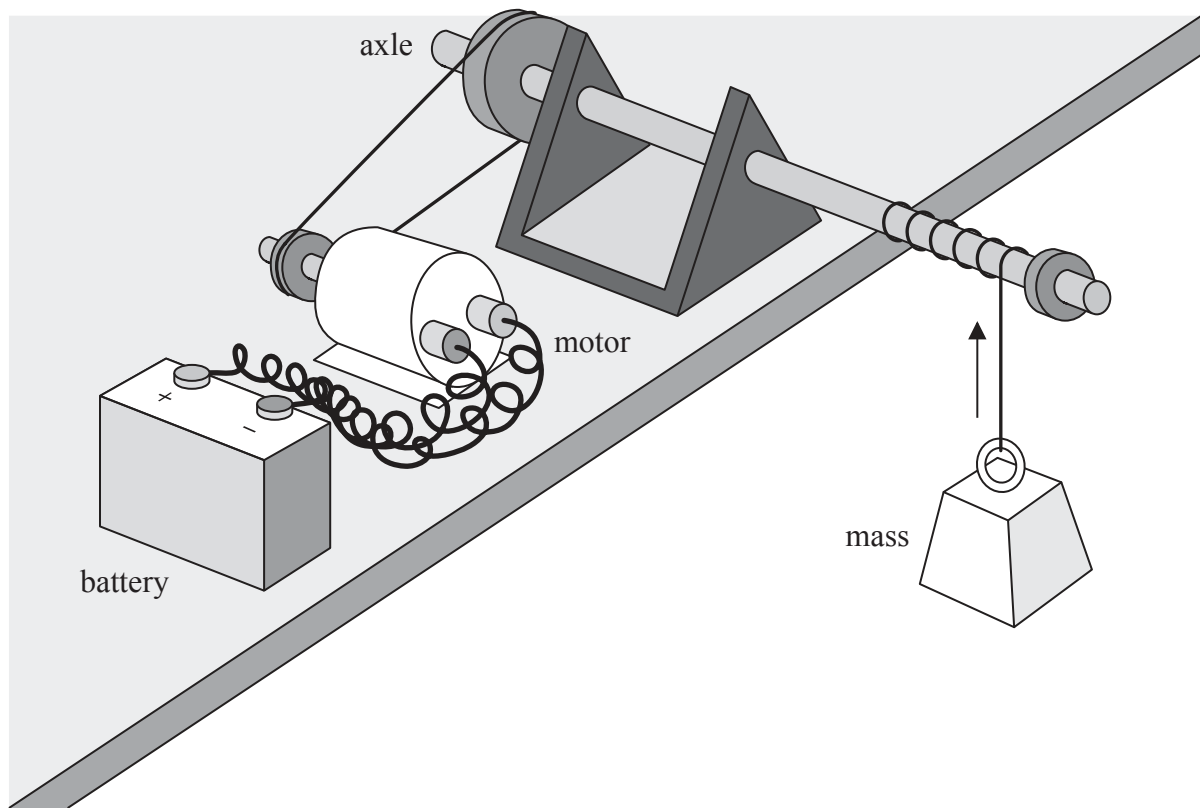

Write a plan for an experiment to do this.

You should:

- state the quantities to be measured, (2)
- explain your choice of measuring instrument for **two** of these quantities, (4)
- comment on whether repeat readings are appropriate in this case, (1)
- explain how the data collected will be used to calculate the efficiency of the motor, (3)
- identify the main sources of uncertainty and/or systematic error, (2)
- comment on safety. (1)

DO NOT WRITE IN THIS AREA

DO NOT WRITE IN THIS AREA

DO NOT WRITE IN THIS AREA



DO NOT WRITE IN THIS AREA

DO NOT WRITE IN THIS AREA

DO NOT WRITE IN THIS AREA

Handwriting practice area with 20 horizontal dotted lines.



DO NOT WRITE IN THIS AREA

DO NOT WRITE IN THIS AREA

DO NOT WRITE IN THIS AREA

(Total for Question 7 = 13 marks)



DO NOT WRITE IN THIS AREA

DO NOT WRITE IN THIS AREA

DO NOT WRITE IN THIS AREA

BLANK PAGE



- 8 A student carried out an experiment to investigate the stretching of a length of rubber of rectangular cross-section. His results are shown below.

original length of rubber = 0.15 m

thickness of rubber = 1.05×10^{-3} m

width of rubber = 2.71×10^{-3} m

Extension / m	Force / N
0	0
0.0225	3.9
0.05	7.9
0.13	9.8
0.235	12.4
0.3	14.0
0.35	18.5

- (a) Criticise these results.

(2)

.....

.....

.....

.....

.....

- (b) (i) Plot a graph of force on the y -axis and extension on the x -axis and draw a line of best fit.

(4)



DO NOT WRITE IN THIS AREA

DO NOT WRITE IN THIS AREA

DO NOT WRITE IN THIS AREA

Force / N

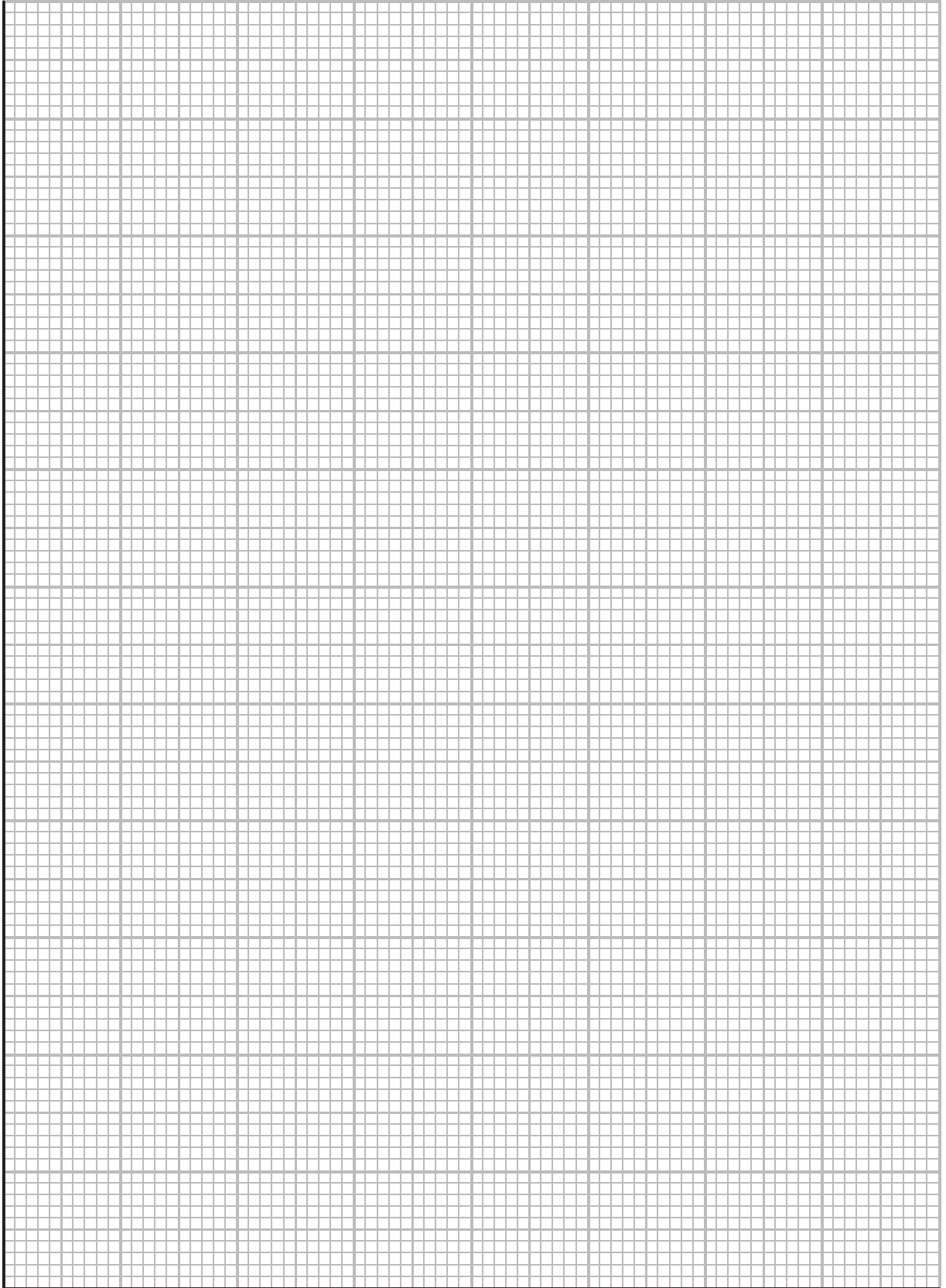

Extension / m

Question 8 continues on the next page



(ii) Comment on the shape of the graph.

(2)

.....

.....

.....

(iii) The area under the graph represents the work done in stretching the rubber.
Determine the work done in stretching the rubber by 0.2 m.

(4)

.....

.....

.....

.....

.....

.....

Work done =

DO NOT WRITE IN THIS AREA

DO NOT WRITE IN THIS AREA

DO NOT WRITE IN THIS AREA



DO NOT WRITE IN THIS AREA

DO NOT WRITE IN THIS AREA

DO NOT WRITE IN THIS AREA

(c) For the last set of results in the table calculate the stress and strain. State an assumption you have made.

(6)

Stress =

Strain =

Assumption

(Total for Question 8 = 18 marks)

TOTAL FOR SECTION B = 35 MARKS

TOTAL FOR PAPER = 40 MARKS



List of data, formulae and relationships

Acceleration of free fall	$g = 9.81 \text{ m s}^{-2}$	(close to Earth's surface)
Electron charge	$e = -1.60 \times 10^{-19} \text{ C}$	
Electron mass	$m_e = 9.11 \times 10^{-31} \text{ kg}$	
Electronvolt	$1 \text{ eV} = 1.60 \times 10^{-19} \text{ J}$	
Gravitational field strength	$g = 9.81 \text{ N kg}^{-1}$	(close to Earth's surface)
Planck constant	$h = 6.63 \times 10^{-34} \text{ J s}$	
Speed of light in a vacuum	$c = 3.00 \times 10^8 \text{ m s}^{-1}$	

Unit 1

Mechanics

Kinematic equations of motion

$$v = u + at$$

$$s = ut + \frac{1}{2}at^2$$

$$v^2 = u^2 + 2as$$

Forces

$$\Sigma F = ma$$

$$g = F/m$$

$$W = mg$$

Work and energy

$$\Delta W = F\Delta s$$

$$E_k = \frac{1}{2}mv^2$$

$$\Delta E_{\text{grav}} = mg\Delta h$$

Materials

Stokes' law

$$F = 6\pi\eta rv$$

Hooke's law

$$F = k\Delta x$$

Density

$$\rho = m/V$$

Pressure

$$p = F/A$$

Young modulus

$$E = \sigma/\epsilon \text{ where}$$

Stress $\sigma = F/A$

Strain $\epsilon = \Delta x/x$

Elastic strain energy

$$E_{\text{el}} = \frac{1}{2}F\Delta x$$

DO NOT WRITE IN THIS AREA

DO NOT WRITE IN THIS AREA

DO NOT WRITE IN THIS AREA



Unit 2

Waves

Wave speed

$$v = f\lambda$$

Refractive index

$${}_1\mu_2 = \sin i / \sin r = v_1 / v_2$$

Electricity

Potential difference

$$V = W/Q$$

Resistance

$$R = V/I$$

Electrical power, energy and efficiency

$$P = VI$$

$$P = I^2R$$

$$P = V^2/R$$

$$W = VIt$$

$$\% \text{ efficiency} = \frac{\text{useful energy output}}{\text{total energy input}} \times 100$$

$$\% \text{ efficiency} = \frac{\text{useful power output}}{\text{total power input}} \times 100$$

Resistivity

$$R = \rho l/A$$

Current

$$I = \Delta Q / \Delta t$$

$$I = nqvA$$

Resistors in series

$$R = R_1 + R_2 + R_3$$

Resistors in parallel

$$\frac{1}{R} = \frac{1}{R_1} + \frac{1}{R_2} + \frac{1}{R_3}$$

Quantum physics

Photon model

$$E = hf$$

Einstein's photoelectric equation

$$hf = \phi + \frac{1}{2}mv_{\text{max}}^2$$

DO NOT WRITE IN THIS AREA

DO NOT WRITE IN THIS AREA

DO NOT WRITE IN THIS AREA



DO NOT WRITE IN THIS AREA

DO NOT WRITE IN THIS AREA

DO NOT WRITE IN THIS AREA

BLANK PAGE

